



PATIENT/CAREGIVER INSTRUCTIONS

# Liquid Oxygen



Follow all warnings and instruction labels on  
medical devices.

To obtain a copy of the manufacturer's product manual,  
visit us at **apria.com**

## Table of Contents

Oxygen.....	1
Your Liquid Oxygen System.....	2
Your Stationary Reservoir .....	2
Operating Your Stationary Reservoir.....	2
Your Portable Unit .....	4
Operating Your Portable Unit .....	5
Refilling Your Portable Unit .....	6
Maintaining Your Liquid Oxygen System ....	8
Care of Your Humidifier Bottle.....	8
Care of Your Oxygen Tubing .....	9
Reordering Oxygen.....	10
Physical Problems.....	11
Handwashing Technique.....	11
Oxygen Safety Precautions .....	11
Travel Tips .....	13
Troubleshooting .....	14
Feedback on Our Services.....	15

## Oxygen

Oxygen is a prescribed drug. **Never increase or decrease your oxygen flow rate without the specific approval of your physician.**

If your physician changes your oxygen flow rate or hours of use, notify Apria Healthcare immediately.

All people need oxygen in order to live. Oxygen is a gas that we can't see, taste, or smell, yet is always there in the air which surrounds us. The amount of oxygen in the air is always 21%.

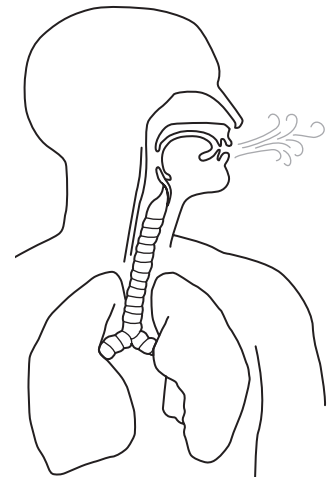

*The respiratory system*

Oxygen is inhaled into our lungs and is then transported through the blood to all parts of the body. Oxygen helps convert food to heat and energy. This process is called metabolism. When the respiratory system is working properly, oxygen is inhaled and transported to the cells with ease. Carbon dioxide, a by-product of metabolism, is then returned to the lungs and exhaled.

## Using Supplemental Oxygen

The 21% concentration of oxygen in the air around us is enough for people with normally functioning lungs and heart. However, a person with lung or heart problems may often benefit from breathing air which has a higher concentration of oxygen in it.

When the body does not get enough oxygen, a person may experience difficulty in breathing, fatigue, loss of memory, headaches and/or confusion. Using supplemental oxygen may help provide relief from these symptoms.

## Your Liquid Oxygen System

When oxygen is cooled to a very low temperature (around 300 degrees below zero Fahrenheit), it becomes a liquid. In the liquid form, large amounts of oxygen can be stored in a container at quite low pressure. This provides not only a large storage capacity, but also allows for filling and refilling of a smaller unit from the large unit.

To remain in the liquid form, the oxygen must continue to be kept very cold. Therefore, the units in which the liquid oxygen is stored are insulated canisters similar to large Thermos® bottles. As the liquid oxygen leaves the container, it warms up to room temperature and becomes a gas again.

A liquid oxygen system usually includes two units: a **stationary reservoir** and a **portable unit**.

## Your Stationary Reservoir

The liquid oxygen stationary reservoir is a large unit. The stationary reservoir can store over 75 pounds of liquid oxygen.

For most patients, this will last from four to eight days.

Stationary reservoirs are available in different sizes and models. However, all models have the same basic parts: a **contents indicator** that shows the amount of oxygen in the unit, a **flow selector** that regulates the amount of oxygen you receive, a **filling connector** that allows the

portable unit to be filled, and, if recommended by your physician, a **humidifier bottle**.

The oxygen is delivered to you through a nasal cannula or face mask. The tubing on the cannula or mask is attached to the outlet nipple or, if recommended by your physician, the humidifier outlet bottle nipple. Sometimes, an extra length of tubing may be attached. This will allow you to move about at a farther distance from your stationary reservoir.

## Operating Your Stationary Reservoir

The following step-by-step instructions will help you operate your stationary reservoir. If your physician has specified a humidifier with your stationary reservoir, go to Step 2.

**Step 1:** Attach a nipple adapter to the reservoir outlet tube and attach the oxygen tubing to the nipple outlet. Check the condensation bottle frequently and empty as required. If you do not empty when full, water will overflow the container.

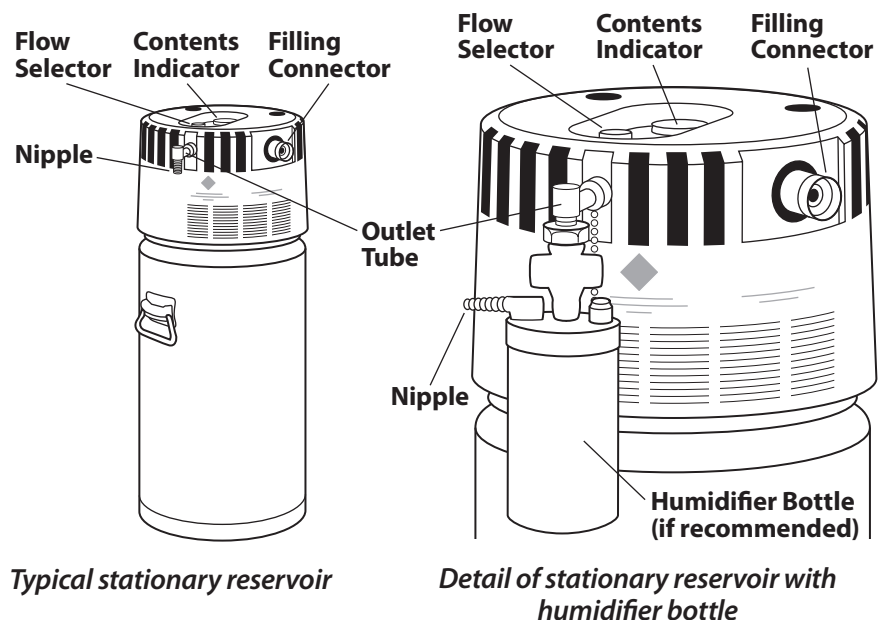

**Step 2:** If recommended, attach a filled humidifier bottle.

- Center the threaded cap on the humidifier bottle under the threaded outlet tube on the reservoir. **Note: Cross-threading the cap on the humidifier bottle will cause oxygen to escape out the top of the bottle.**
- Turn the cap on the humidifier bottle until it is tightly screwed onto the outlet tube.
- Attach oxygen tubing to the nipple outlet on the humidifier bottle lid.

**Note:** Humidifier bottles are generally recommended only for patients using flow rates greater than four liters per minute.

**Step 3:** Adjust the oxygen flow rate by turning the rotary flow control dial until the prescribed liter number appears and the switch clicks into position.

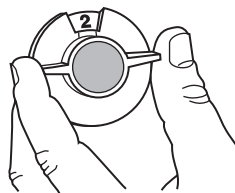

*Adjust flow rate*

**Step 4:** Fit the nasal cannula or the oxygen mask to your face so it is comfortable. Follow the instructions below for either the nasal cannula or oxygen mask, depending on which one your physician has prescribed.

### Nasal Cannula

- Insert the two prongs of the cannula into your nostrils. Make sure the prongs face upward and curve into your nostrils.
- Slide the tubing over and behind each ear.
- Adjust the tubing to fit comfortably under your chin by sliding the adjuster upward. Be careful not to adjust it too tightly.

### Oxygen Mask

- Place the oxygen mask over your mouth and nose.
- Slide the loose elastic strap over your head and position it above your ears.
- Pull the end of the elastic on each side of the mask until the mask fits comfortably.
- Pinch the metal nose strap to fit snugly around your nose. This will prevent oxygen from blowing into your eyes.

**Note: Do not use an oxygen mask if your physician prescribed a nasal cannula.**

Oxygen masks must only be used with liter flow rates of five liters (or more) per minute.

Always use your oxygen at the proper flow rate for the number of hours each day your physician has prescribed.

**Step 5:** When you have finished using your oxygen, always:

- Remove the nasal cannula or the oxygen mask.
- Turn the liter control knob off.

**Note:** *Every day*, check the amount of oxygen remaining in your stationary reservoir so you will know when to order a refill. Refer to the list below for instructions on how to read the indicator on your reservoir.



*Adjust nasal cannula*



*Adjust oxygen mask*

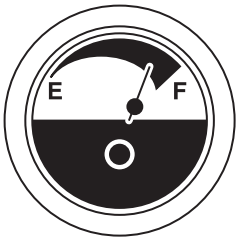

Typical needle gauge

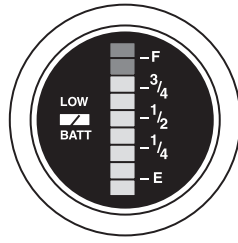

Typical bar-type gauge

### Needle Gauge

The position of the needle will tell you approximately how much oxygen is left in the reservoir. You may have to depress a push button on the top of the reservoir to light up the meter face and cause the needle to register.

### Bar-Type Gauge

Depress the red button on the top of the reservoir. Look at the lighted bar on the gauge to see approximately how much oxygen is left in the reservoir.

### Weight Scale Base

The position of the metal pointer on the scale under your reservoir will tell you approximately how much oxygen is left in your reservoir.

## Contents Guide: Stationary Reservoir

Your oxygen flow is measured in liters per minute (LPM). Average oxygen usage time is based on **continuous** flow rate. The figures in the chart (above) for different brands of stationary reservoirs are **approximate** and should be used only as a **general guide**.

Individual usage time will vary.

If you are at all concerned about when to order

## Stationary Reservoir

Approximate Use Time in Hours

Liter Flow	Puritan-Bennett Companion 21	Puritan-Bennett Companion 31	Puritan-Bennett Companion 41	Caire Liberator 30	Caire Liberator 45
1	288	425	562	333	483
2	144	212	281	166	242
3	96	141	187	111	161
4	72	106	140	83	121
5	57	85	112	67	97

an oxygen refill, please contact the Oxygen Scheduling Department at (855) 869-9436.

## Your Portable Unit

The portable liquid oxygen unit is a small unit which is intended to be used during activities outside the home. Depending on the size, the portable unit weighs seven to ten pounds when full and will provide four to eight hours of continuous oxygen for most patients.

**Actual use times will vary depending on your liter flow.**

The portable unit can be simply and conveniently filled from the stationary reservoir. The unit is carried by means of a shoulder strap or lightweight wheeled cart.

Portable liquid units are available in different sizes and models but all have the same basic parts: a **flow control knob** which provides the desired flow of oxygen, an **oxygen contents gauge** which tells you approximately how much oxygen remains in the unit, a **filling connector** which allows you to attach the

portable unit to the stationary reservoir for refilling, an **oxygen outlet** to which your **oxygen tubing** attaches, and a **shoulder strap** which allows you to comfortably carry your unit.

## Condensation Pad

Some portable units have a condensation pad on the bottom of the unit. If the pad gets wet, remove the plastic cover and pad and allow the pad to air dry before using the portable unit.

## Operating Your Portable Unit

The following step-by-step instructions will help you operate your portable liquid oxygen unit.

**Step 1:** Check the amount of liquid oxygen in your unit. When the portable unit is not in use, the liquid oxygen it contains will evaporate

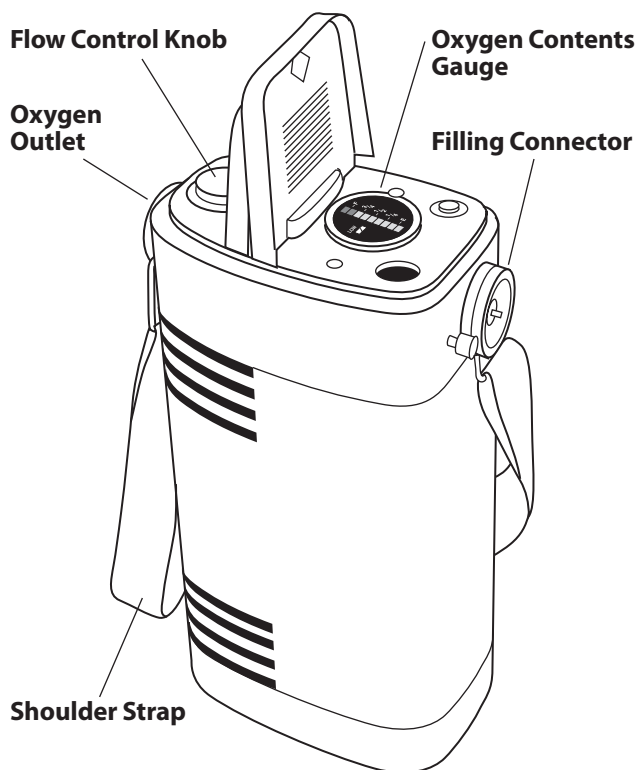

*Typical portable liquid oxygen unit*

within 24 hours. Be sure your unit has enough oxygen in it to accommodate your expected usage time. If you are unsure, contact your Apria representative.

### **Needle Gauge** (shown on page 4)

The position of the needle will tell you approximately how much oxygen is left in the portable unit. You may have to depress a push button on the unit to light up the meter face and cause the needle to register.

### **Bar-Type Gauge** (shown on page 4)

Depress the red button on top of the unit. Look at the lighted bar on the gauge to see approximately how much oxygen is left in the unit.

**Step 2:** Attach the oxygen tubing to the oxygen outlet on the side of the unit.

**Step 3:** Adjust the oxygen flow by turning the knob until the prescribed liter number appears and the switch clicks into position.

**Caution:** The portable oxygen unit will not deliver oxygen to you if the control knob is set between flow settings. Be sure the switch clicks into position and shows the prescribed setting.

**Step 4:** Most portable units need to be kept upright. Refer to the manufacturer's warning labels on your device. Call Apria if you have any questions.

**Warning:** ⚠ If the unit is accidentally tipped over, you may hear hissing and see oxygen vapor escaping. Place the unit upright immediately.

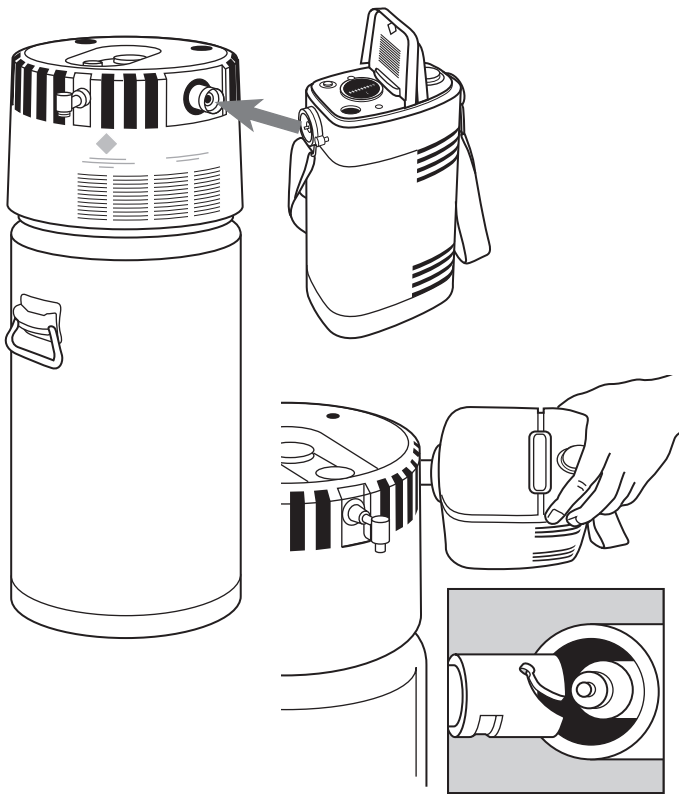

*Attaching portable units to stationary reservoirs*

of the reservoir. Use the following instructions, depending on the type of unit you use:

### Side Mount Refill

- a. Tilt the portable unit counter-clockwise to a 45-degree angle.
- b. Insert the portable unit connector into the reservoir connector.
- c. Rotate the portable unit clockwise to an upright position until the pin locks into place. You should not have to force it to rotate. Continue to Step 4 below.

### Top Mount Refill (shown on page 7)

- a. Center the portable unit connector over the reservoir connector; OR
- b. Lower the unit into the shaped recess or onto the connector. Once the unit is resting on the connector, rotate it clockwise until the pin locks into place and you feel firm resistance.

## Refilling Your Portable Unit

To refill your portable liquid oxygen unit from the stationary reservoir, follow these steps:

**Step 1:** Wipe the filling connectors on both the portable unit and the stationary reservoir with a clean lint-free cloth. These fittings must be dry. Moisture could cause the units to freeze together.

**Step 2:** On the portable unit, turn the flow control knob to the off position.

**Step 3:** Attach the portable unit to the stationary reservoir at the filling connectors. Some units refill from the side of the reservoir, while others refill at the top

**Step 4:** Open the fill valve by either depressing the fill button or using a key (depending on your specific model). This valve is found either on the reservoir or on the portable unit.

- This will start the filling process.
- As the unit is filling, you will hear a hissing noise.

#### SIDE MOUNT REFILL

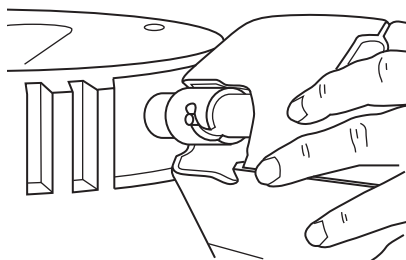

*Tilt the portable unit and insert the connector*

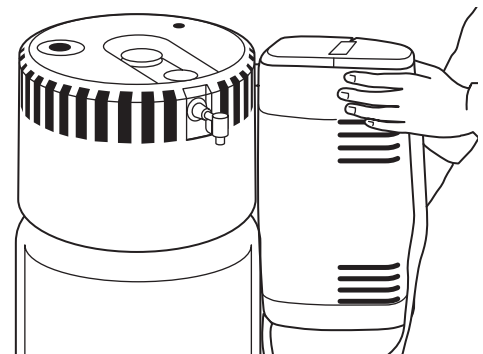

*Rotate the portable unit clockwise to an upright position*



- When the unit is full, the hissing noise will change and you may see a small cloud of white vapor at the connection.
- **Always watch the units carefully while filling; do not leave unattended.** Fill time is approximately two minutes.

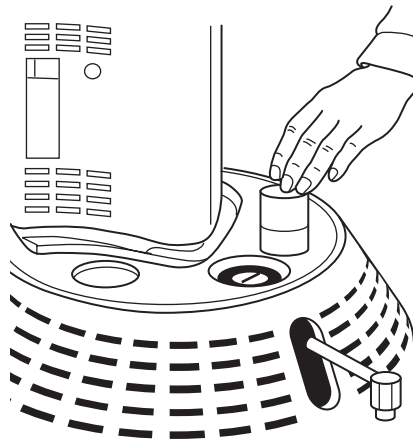

*Opening the fill valve on the reservoir*

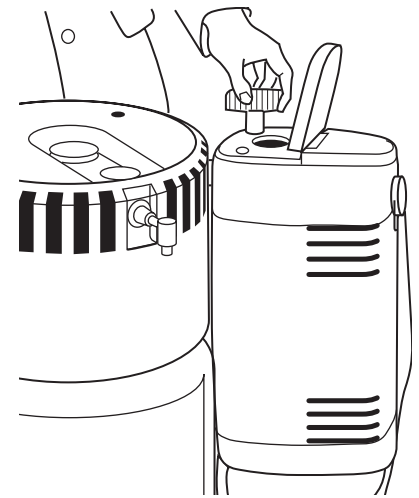

*Opening the fill valve on the portable unit*

**Step 5:** When the unit is full, slowly close the fill valve.

**Step 6:** Disengage the portable unit from the stationary reservoir.

- If the portable unit does not separate easily, do not force it. The units may be frozen together. Wait until the units warm up and they will separate easily.

**Caution: DO NOT TOUCH** any frosted parts of the connectors. Liquid oxygen can cause frostbite to the skin.

**Step 7:** Reattach the oxygen tubing to the oxygen outlet on the portable unit. Your unit is now ready for use.

**Important Note:** Liquid oxygen will slowly evaporate from a portable unit. To avoid

excessive waste, fill the portable unit just before use.

**Caution:** If the portable and stationary units do not separate easily, do not use force. The units may be frozen together. Wait until the units warm up — then they'll separate easily. Do not touch any frosted parts. If there is any liquid leakage after separation, reattach the units immediately. Again separate the units. If the problem persists, leave units coupled and call Apria Healthcare.

**Warning:** ⚠ **If the leakage is excessive to the point that a stream of liquid is present, leave the area and call Apria immediately.**

**Caution:** Always store the portable unit in a well-ventilated area.

**TOP MOUNT REFILL**

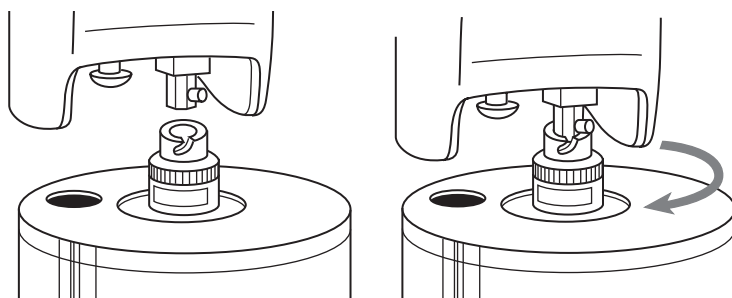

*Center the portable unit connector*

*Lower the portable unit and rotate*

**Contents Guide: Portable Unit** (shown on page 8)

Your oxygen flow is measured in liters per minute (LPM). Average oxygen usage time is based on **continuous** flow rate. The figures (in the chart on page 8) for different brands of portable

## Portable Reservoir

Approximate Use Time in Hours (h) and Minutes (m)

Liter Flow	Puritan-Bennett Companion 500	Puritan-Bennett Companion 550	Puritan-Bennett Companion 1000	Caire Stroller
1	9h	13h 30m	15h 30m	11h 45m
2	4h 40m	6h 30m	8h 30m	6h 20m
3	3h	6h 30m	5h 48m	4h
4	2h 12m	5h 6m	4h 18m	3h 15m
5	1h 48m	4h 12m	3h 24m	2h 40m

units are **approximate** and should be used only as a **general guide**. Individual usage time will vary.

Since this guide is an approximation, always add an extra 30 minutes when estimating your portable oxygen needs.

## Maintaining Your Liquid Oxygen System

As necessary, you should wipe the outside of your units with a clean damp cloth. **Never** use wax, cleaning sprays or furniture polish. Many of these products are flammable.

You should **never** open either of your own units or attempt any repairs on them. **Never** use grease, oil or other lubricants on your units. Many lubricants are volatile and could cause a safety hazard.

Should you have any problems with your liquid



*Never use wax, cleaning sprays or furniture polish on liquid oxygen units*

oxygen system at any time, call Apria Healthcare immediately. We are available 24 hours a day, seven days a week, for emergencies.

## Care of Your Humidifier Bottle

It is important to clean and disinfect your respiratory therapy equipment regularly. To prevent equipment contamination, a simple but effective cleaning procedure must be performed as described below.

Do all cleaning and disinfecting in a clean environment. Avoid cleaning equipment immediately after vacuuming, under an open window, or in dusty, dirty, smoky areas.

If you are using a humidifier bottle with your oxygen system, you also need to check the water level in the bottle frequently. When the water runs low or the bubbling stops, refill the bottle.

**Note: Always use your back up oxygen system while refilling and cleaning your humidifier bottle.**

## Refilling the Humidifier Bottle

**Step 1:** Wash your hands as instructed on page 11.

**Step 2:** Turn your oxygen off.

**Step 3:** Unscrew the bottle from the humidifier bottle lid.

**Step 4:** Discard any water remaining in the bottle.

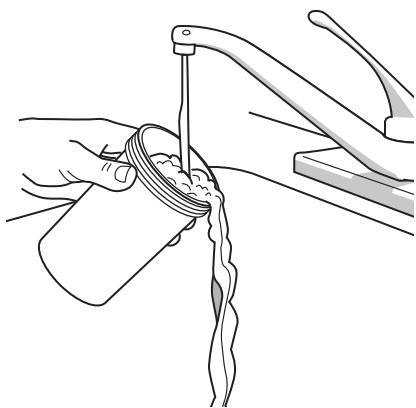

*Rinse bottle under a strong stream of warm tap water*

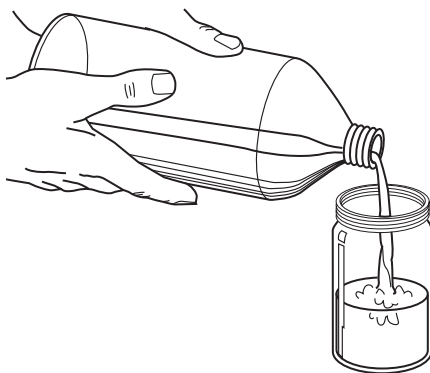

*Refill the bottle with distilled water*

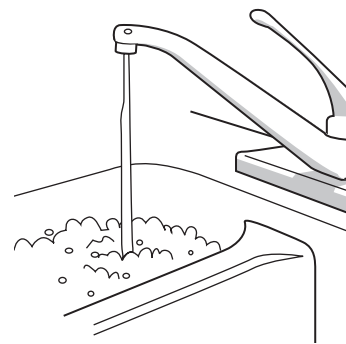

*Wash the humidifier bottle every 3 days*

**Step 5:** Rinse the bottle under a strong stream of warm tap water. Shake off the excess water.

**Step 6:** Refill the bottle with distilled water to the fill line. Do not overfill the bottle. Too much water in the bottle will cause water to collect in your oxygen tubing.

**Step 7:** Screw the bottle back on the humidifier bottle lid until it is tight. Be certain the bottle is screwed on straight. Cross-threading will cause oxygen to escape out the top of the bottle.

## Twice Weekly Cleaning and Disinfection

It is very important to clean your humidifier bottle to prevent infection. The following procedure should be done *twice a week*:

**Step 1:** Wash your hands as instructed on page 11.

**Step 2:** Turn the oxygen off.

**Step 3:** Remove the humidifier bottle.

**Step 4:** Wash the entire humidifier bottle in a solution of liquid detergent and warm water.

**Step 5:** Rinse the bottle thoroughly. Shake off the excess water.

**Step 6:** Mix one part white vinegar and one part water.

**Step 7:** Soak humidifier bottle for 30 minutes in the vinegar solution.

**Step 8:** Discard the vinegar solution.

**Step 9:** Rinse the bottle thoroughly in warm tap water.

**Step 10:** Allow the bottle to air dry.

**Step 11:** Replace your humidifier bottle as instructed above.

## Care of Your Oxygen Tubing

Minimal care is required of your oxygen tubing and nasal cannula or oxygen mask. We recommend that once or twice during the day, you remove the cannula or mask and wipe it clean with a damp cloth. You should discard and replace your nasal cannula or oxygen mask once a month.

**Discard and replace your tubing once every 6 months.**

**Caution:** Do not use alcohol or oil-based products on or near your cannula or mask.

Moisture may accumulate inside the oxygen tubing, especially

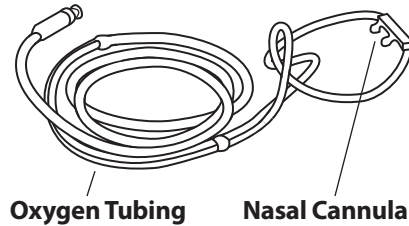

if you are using a humidifier bottle. Excess moisture may reduce oxygen flow. If this happens you may try the following steps:

**Note:** You should use your back-up oxygen system while refilling and cleaning your humidifier bottle.

**Step 1:** Remove the humidifier bottle from the outlet tube on the liquid oxygen stationary reservoir.

**Step 2:** Attach a nipple adapter to the outlet tube.

**Step 3:** Remove the oxygen tubing from the humidifier bottle and attach it to the nipple adapter.

**Step 4:** Allow the oxygen to run directly through the tubing. Within a few minutes, the tubing will be dry.

**Step 5:** When the tubing is dry, disconnect it and remove the nipple adapter. Reconnect the humidifier bottle to the liquid oxygen stationary reservoir and reattach the oxygen tubing to the humidifier bottle.

**Step 6:** Check the liter flow to make sure the oxygen is flowing at the prescribed level.

**Note:** If excess moisture is a recurrent problem, be sure to call your Apria location to request a “water trap.”

## Reordering Oxygen

Always be aware of the amount of oxygen remaining in your stationary reservoir.

You will most likely be on an automatic delivery schedule, but always knowing how much oxygen you have will prevent any worry of running out before your next supply is delivered.

In order to provide the best possible service to our oxygen customers Apria has developed the following oxygen resupply process.

Several days prior to your scheduled delivery day, you will receive an automated call from our scheduling department:

- Listen to the prompts to confirm the need for your resupply order.
- Press “1” to enter the confirmation queue, then press “1” to confirm your need for a refill, or “2” to decline your refill order.
- Declined refills will automatically be set to the next scheduled delivery day based on your cycle and frequency.

If you are not on an automatic delivery schedule, reorder oxygen two days before your stationary reservoir has been calculated to run out. **Please contact your local Apria branch. Branch phone numbers can be found on Apria.com by selecting the FIND A BRANCH option at the top of the web site.** Call this number if you believe you do not have enough oxygen to make it to your next scheduled delivery. This will allow Apria Healthcare to schedule your delivery without causing you to worry.

Consult the table on page 4 for guidelines on the approximate length of time for use of your unit.

## Physical Problems

If you experience any of the following problems, call your physician:

- Fever or chills
- Increased wheezing
- Increased mucus production
- Mucus becomes thicker
- Change in mucus color
- Headaches
- Loss of appetite
- Increased shortness of breath
- Chest pain
- Increased cough
- Swelling in your ankles or around your eyes
- Weight gain overnight
- Feeling dizzy or sleepy
- Any change in physical sensation after taking a new medication

If you experience **severe physical problems**, call 911 or your local emergency services.

If you experience any **physical change**, call your physician.

If you are having trouble with your **equipment**, call Apria Healthcare.

## Handwashing Technique

Thorough handwashing must be done prior to all procedures. Contaminated, dirty hands are one of the most common sources of infection.

1. Wet your hands thoroughly with warm water.

2. Use soap.
3. Scrub hands for 20 seconds using a rotary motion and friction. Wash:
  - Back and palm of each hand
  - Between all fingers
  - Fingernails

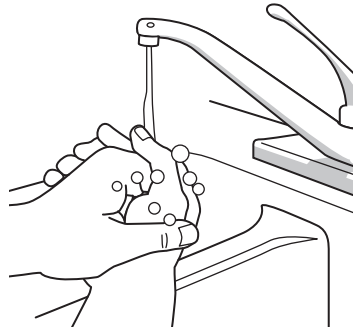

*Wash hands for 20 seconds*

Need a timer? Hum the “Happy Birthday” song from beginning to end twice.

4. Rinse your hands under the running water.
5. Dry on clean towel or with a paper towel.

For additional good health habits, visit our Patient Education section on [apria.com](http://apria.com).

## Oxygen Safety Precautions

Oxygen can be used safely when handled and stored properly. By using the following safety guidelines, you will create a safe environment when you use your oxygen.

For safety reasons, it is recommended that you install smoke alarms outside each sleeping area and on each level in the home. Fire extinguishers are also recommended.

**Warning:**  Heat

**Keep oxygen equipment and oxygen tubing at least five (5) feet away from any source of heat.**

Keep the oxygen equipment and oxygen tubing away from open flames, stoves, space heaters, or any source of heat.

## **Warning:** **Grease/Flammables**

**Never use grease or oil on oxygen equipment.**

Keep oxygen equipment away from all flammable materials such as oil, grease, aerosols, paints, gasoline and solvents. Hand, hair or body lotions should not come in contact with oxygen equipment.

## **No Smoking**

**Do not permit smoking in the same room as your oxygen equipment. This includes electronic cigarettes (e-cigarettes).**



Place “**No Smoking**” signs on the front door or in a front window of your residence. Apria also encourages you to post “No Smoking” signs in the room where your equipment is in use.

It is possible for you to be in a large room such as a restaurant where smoking is permitted as long as lighted smoking materials are not within five (5) feet of you. Nevertheless, when visiting restaurants, always ask to sit in the no smoking section.

## **Cooking**

It is best to cook using a microwave oven only. Cooking on a gas or electric stove is not recommended.

## **Storage**

**Do not place your oxygen equipment in a small or unventilated storage area.**

Do not place oxygen equipment in a small storage area such as a closet or car trunk. Any venting oxygen could create a fire hazard.

## **Oil-Based Toiletries and Small Appliances**

**When using oxygen, never use oil-based face or hair creams, a hair dryer or an electric razor.**

It is possible in certain conditions that the combination of oxygen, oil-based toiletries, and a spark from an electrical appliance such as an electric blanket, hair dryer, electric razor or heating pad, could ignite and cause burns. Never use oil-based hair lubricants, face and hand lotions, petroleum jelly products, or aerosol sprays. Always use water-based cosmetics or creams.

## **Frost Burns**

**Never touch the frosted connectors on the liquid units.**

Liquid oxygen is chilled to about 300 degrees below zero Fahrenheit. If you touch one of the frosted parts on your unit, it is possible that you will receive a skin burn.

**If contact occurs, generously flush with cold water and call your physician.**

## **Moving Your System**

Never move the stationary reservoir without consulting your Apria Healthcare location.

## **Spillage**

**Keep the liquid oxygen equipment upright at all times.**

---

If your liquid unit falls over on its side, it is possible for a stream of liquid oxygen to spill out of the reservoir. To avoid spillage, keep the stationary unit upright at all times. If a spill occurs, open doors and windows to ventilate the area and call Apria immediately.

Most portable units also need to be kept upright. Refer to the manufacturer's warning labels on your device. Call Apria if you have any questions.

## Home Address

**Make sure your home address can be easily seen from the street during both day and night.**

Check to see that your address numbers are easy to spot and read from the street. If you are expecting a night delivery or visit, turn on the porch light. This will allow all Apria Healthcare and emergency personnel to locate your residence easily.

## Emergencies and Natural Disasters

In the event of an emergency or natural disaster, follow the internet, radio or television emergency instructions broadcast by your local authorities.

## Travel Tips

Early planning and careful preparation are the keys to an enjoyable trip. The following tips should help you plan and prepare for any trip.

- Contact your physician to make sure your proposed trip is medically safe and to obtain additional copies of your prescription.

- Contact Apria Healthcare for assistance with getting oxygen refills along your driving route or at your final destination. Apria offers its Great Escapes™ program to assist with your travel arrangements. Contact Apria's Great Escapes National Travel Department **at least six weeks** prior to your travel date by calling us at **1 (844) 235-2738** and selecting the Travel Department.
- Have a check, money order or credit card available to pay for oxygen refills or equipment. Cash is not accepted.

## If traveling by car or recreational vehicle:

- Remind passengers not to smoke in the vehicle in which you are traveling.
- Securely fasten tanks.
- Keep one window partially open to provide proper ventilation.
- **Do not** store oxygen in the trunk of your car.
- **Do not** store oxygen in an area where the temperature will reach 120 degrees Fahrenheit.
- Keep liquid oxygen in an upright position.
- When traveling in or occupying a recreational vehicle, do not store oxygen near gas or an open flame.
- Stay at least five feet away from all open flames, such as camp stoves, lanterns, and heaters.
- Never refill your portable unit inside your car or recreational vehicle.

## If traveling by bus, train or ship:

- Contact the reservation office for specific information about the use of oxygen and special accommodations.
- Make sure to contact Apria **at least four weeks** in advance. There may be additional documentation, forms or releases required. There may also be additional fees required.

## If traveling by airplane:

- Visit our website at [apria.com](http://apria.com), select **Apria's Travel Support**, then select **Portable Oxygen Concentrator request form**. Print this form, complete the patient page and have your physician complete the physician's page. Return these completed pages to your local Apria branch **at least three to four weeks** before your departure date.
- Many airlines also have forms that need to be completed by your physician. You should contact your airline provider to advise them that you will be travelling

with oxygen and get any forms that they require.

- Request a direct flight, if one is available.
- Apria Healthcare offers its Great Escapes program to assist with your travel arrangements. Contact Apria Healthcare's Great Escapes National Travel Department **at least six weeks** prior to your travel date by calling us at **1 (844) 235-2738** and selecting the Travel Department.
- Most airlines allow patients to bring portable oxygen concentrators on board. As part of Apria Great Escapes travel program, Apria can provide most patients with a portable oxygen concentrator that is allowed on most airlines.
- Before you depart on a plane, ensure that arrangements have been made to obtain oxygen at your final destination.

For further information, please contact Apria Healthcare's Great Escapes National Travel Department at **1 (844) 235-2738**, then select the Travel Department.

## Troubleshooting

Trouble	Probable Cause	Remedy
No oxygen coming from cannula or mask	Decreased awareness of oxygen flow	Place cannula prongs in a clean glass of water. If you observe bubbles coming from your cannula, your unit is working correctly.
	Loose connections	Check each connection from the unit to the cannula to ensure a tight fit. If you are using a humidifier bottle, check to see that it is screwed on tight and is not cross-threaded.
	Flow control knob is not pointing directly to setting	Adjust flow knob to point directly to prescribed setting.



Trouble	Probable Cause	Remedy
No oxygen coming from cannula or mask <i>(continued)</i>	Unit is empty	Call Apria Healthcare for immediate delivery.
	Dirty or faulty cannula or mask	Remove cannula or mask and check tubing for kinks or obstructions. Replace with new cannula or mask if needed.
	Stationary unit obstructed flow	Fill portable and call Apria Healthcare location.
Portable unit cannot be removed from stationary system	Units are frozen together	Wait 15 to 30 minutes for connections to thaw.
Portable unit does not last as long as usual	Not fully filled	Review filling procedure. If problem persists call Apria Healthcare.
Liquid leakage or white vapor spewing out of connector after uncoupling	Fill valve stuck open	Immediately reconnect portable to stationary unit. Again separate the units. If the problem persists, leave units coupled and call Apria. <b>Warning:</b> If leakage is excessive — a stream of liquid is present — leave the area and call Apria immediately.
All other problems or questions about equipment		Call your Apria Healthcare location.

## Feedback on Our Services

Apria Healthcare is among America’s most experienced and respected home respiratory care providers, and our patient satisfaction scores are consistently high. It is possible, however, that you may have a concern and we welcome feedback. To voice a concern, you should take these steps:

1. Call the Apria Customer Service for Patient Concerns at **1 (800) 260-8808**  
OR

2. Contact us by e-mail at:  
**Patient\_Satisfaction@apria.com**  
OR
3. Visit our web site at **apria.com**

## Satisfaction Survey Process

Our goal is to ensure your satisfaction. You will likely receive an Apria patient satisfaction questionnaire and we hope that you will take a few minutes to fill it out and return it to us. The postage is prepaid by Apria Healthcare.

**Did you know that Apria Healthcare currently provides a home ventilator that can be used with a face or nasal mask? It's called *non-invasive ventilation***

**Non-invasive ventilation** is prescribed for patients with Chronic Respiratory Failure caused by severe Chronic Obstructive Pulmonary Disease (COPD) as well as other conditions that may result in a patient needing extra assistance with breathing.

Patients who benefit from non-invasive ventilation therapy typically have been diagnosed with severe COPD. They often have difficulty performing everyday activities due to shortness of breath; and this happens even though they may already be on oxygen therapy and/or using inhaled respiratory medications.

**Are you a COPD patient who needs help to breathe easier?**

Ask your doctor or your local Apria branch for more information. Certain qualification requirements do apply, and not all patients with COPD will require non-invasive ventilation.



**What does COPD mean?**

Chronic Obstructive Pulmonary Disease (COPD) is an umbrella term used to describe progressive lung diseases including emphysema, chronic bronchitis, refractory (non-reversible) asthma, and some forms of bronchiectasis.



Visit us at  
[apria.com](http://apria.com)

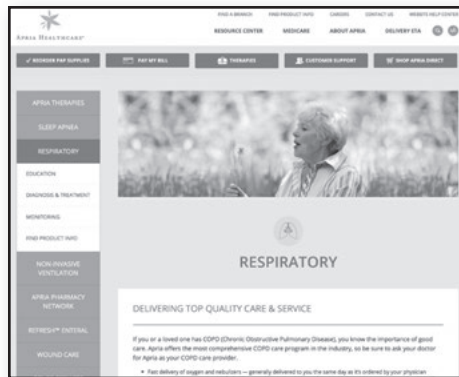

*Education  
News  
Articles  
Services*